

Power the green energy future



GUANGDONG AOKLY GROUP CO., LTD.

📍 Production base: High-tech Industrial Development Zone, Yingde City, Guangdong Province, China

📍 Overseas sales center: Room 110, Block B, Jianpeng Road 402, Baiyun District, Guangzhou

TEL: +86-20-86860028/86861998

FAX: +86-20-86878822

HTTP: WWW.AOKLY-BATTERY.COM

E-mail: Sales@aokly-battery.com



AUTOMOTIVE BATTERY



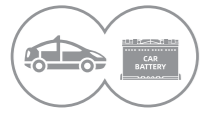

AUTOMOTIVE BATTERY

AOKLY
Series Battery



COMPANY PROFILE



One of the largest manufacturing bases
Of storage battery in the south china

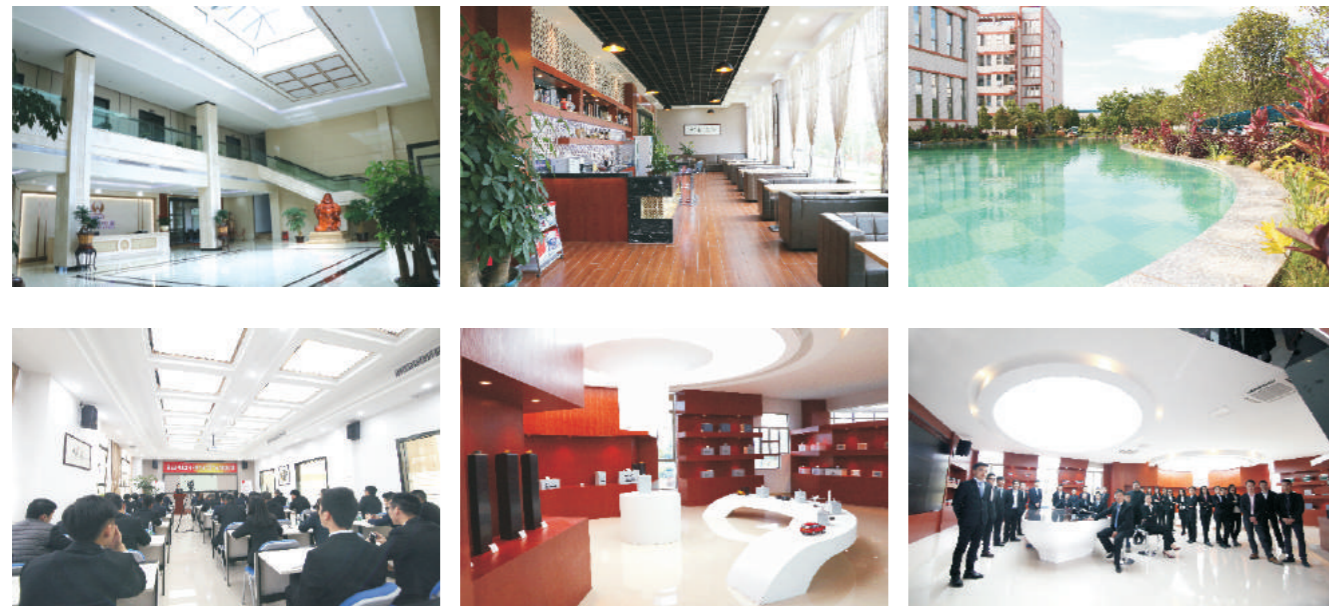

Guangdong Aokly Group Co., Ltd was promoted from Yingde Aokly Power Co.,Ltd , and Yingde Aokly Power Co., Ltd was established on base of former Guangdong Zeliang Storage Battery Co., Ltd since 1996. In September of 2021, for the realization of enterprise globalization strategy, and to further improve the overseas market share, Aokly Power has promoted to Aokly Group , The area of Aokly Group has covering more than 333,500m² in Yingde Huaqiao Industrial Zone, and total investment capital amount is over 2 Billion RMB. Aokly Group has established modern production bases. There are 4 production bases in Aokly Group. Production Base No.1 and No.2,former Guangdong Zeliang Storage Battery Co., Ltd. Located in Yingyuan industrial zone, Qingyuan city, Guangdong province. Production Base No.3, Hongshu Battery Yingde Co., Ltd. Located in Yingde city, Guangdong province. Production Base No.4 located in Huaqiao industrial zone, Yingde city.

With 25 years' experience in Lead Acid battery industry, Guangdong Aokly Group Co., Ltd is currently one of the largest enterprises of storage battery for research and development, production and sales. It mainly produces Fixed Valve Regulated Lead Acid battery, small sized VRLA battery, Golf cart battery, Electric vehicle battery, Starting lead acid storage battery. Aokly Group has over 90 experienced researchers, technicians and managing talents, and importing the most advanced automatic production equipment as well as testing equipment. Furthermore, fully automatic production lines for producing sealed maintenance free storage battery have been in regular operation. Aokly Group imported the automatic machinery from Canada Teck(British TBS), Italy Sovema, Korea Moojin service, Germany Digator, which are most top advanced in the world. Aokly Group present annual capacity can reach 13 Million KVAH and 80K pcs VRLA battery a month .

The product adopts unique producing technology according to perfect quality-control system to arrange production and have respectively passed ISO9001 & ISO 14001 approval in national quality control system and environment system. Meanwhile it gain title national inspection-free product, furthermore be approved by UL, CE, ROHS and the complete IEC60095 testing etc. The battery are widely used in Uninterruptible Power Supplies (UPS), Electric Tools, Medical Equipment, Emergency lighting system, Control System, Communication System, Electric Power System, Solar Power system, Wind Power system, Automobile, Electric vehicle, Golf cart, Tourist Car, Farming Vehicles, etc. They have been sold well both at domestic and overseas market. More than 60 % of sale is for overseas market. In domestic market, we have set up dozens of branches in China to ensure timely service to our customers.

Aokly Group has been always taking a objective that seek best on quality, chase develop on sincerity to create diamond brand in field of Chinese storage battery with top quality and service.



AUTOMOTIVE BATTERY

AOKLY
Series Battery



FACTORY VIEW

PRODUCTION
BASE:
333,500
SQM



Production Capacity



Aokly has four production bases, and importing equipment from Canada, Italy, Germany and Korea to make sure all products are well controlled and it has a stable high production capacity.

To strive for high-grade product quality, our company makes strict inspection and selection on materials which are ensuring high-quality and high-standard materials used in assembling production for all products.



BATTERY STRUCTURE & CHARACTERISTICS

1. **EXPANDED PLATES** : Adopting the complete automatic high performance expanded machinery which is currently the most advanced automatic technology worldwide. The unique Pb-Ca alloy formulation with low water losing has been adopted, enabled the low self-discharge and long shelf life. Furthermore, special solidification process greatly improves the uniformity of plates. Resolving the formation of high resistance PbSO₂ in plate gate interface. Ensuring the battery is always in the strongest cranking performance.
2. **SEPARATOR**: The super- thin glass fiber in separator (or PE envelop) reduces the short circuit of plates group, reduce the electric resistance and increase the current capacity. The surface fiber can protect effectively the positive plate to shake and the powder off, so as to extend the usage life.
3. **POLES**: Mechanical operation ensure no-leakage. Special technical processing, which make sure the poles are more durable than traditional one.
4. **CENTRAL BUSBAR**: Adopting the most advanced COS machine to connect the plates, which is not easy to break and the busbar has high resistance to vibration, low resistance and good electric conductivity.
5. **MAGIC-EYE INDICATOR**: Easy to check charging state.
6. **DUST-PROOF FLAME ARRESTER**: Prevent explosion caused by overflow sulphuric acid and charging spark.
7. **COVER**: With special structure, the battery has the excellent performance of nonleakage, ventilation and anti-explosion, etc.
8. **HEAT SEAL TECHNOLOGY**: Heat sealed design to maximize strength and rigidity to prevent electrolyte leakage.





AUTOMOTIVE BATTERY



SEALED MF STARTING LEAD ACID BATTERIES

Completely sealed Maintenance-Environment Secured, Long-lifespan, Aokly is your reliable partner!



THE CHARACTERISTIC, USAGE AND MAINTENANCE:

1. For a new battery, it's no need to charge, to add liquid, you can use it after fitting on the car. During the usage, liquid is never in need.
2. When using, keep the battery clean, make sure the connection contacts well. Coated some Vaseline on connection between the pole and line and fasten the batteries well.
3. Strong polypropylene container, advance lead calcium alloy and special diachylum method, anti-acid mist filter plate, anti-shake, prevent coldness, low discharge, less water losing, well cold starting capability.
4. If need to offload the battery to charge, you can charge it with constant current of less than 0.1C20A, and keep the voltage in 14.2~14.6V.
5. Keep batteries in a dry place, avoiding the sunshine. Batteries with half year storage, before use, you should charge them. Charging method: 0.1C20A. Eg: 60AH battery: charging with 6A for 6 hours.
6. The battery is suitable for a car with 14.2-14.4V charging voltage.

JIS Standard Battery (SMF)

No.	JIS Gr.NO.	New JIS NO.	Old JIS NO.	Capacity (20HR)	Dimension(mm)				GW (kg)	R C (MINS.)	Lay-out	Terminal	Qty/ Pallet	Hold-Down
					Length	Width	Height	T.Height						
1		U1-33MF		33	195	127	158	186	9.3	40	1	C	256	
2	B19	32B19RMF	NS40	32	195	127	200	220	9.7	48	1	A	224	
3		32B19LMF	NS40L	32	195	127	200	220	9.7	48	0	A	224	
4	B20	36B20RMF	NS40Z	36	195	127	200	220	10.3	52	1	A	224	—
5		36B20LMF	NS40ZL	36	195	127	200	220	10.3	52	0	A	224	—
6		36B20RSMF	NS40Z(S)	36	195	127	200	220	10.3	52	1	B	224	
7		36B20LSMF	NS40ZL(S)	36	195	127	200	220	10.3	52	0	B	224	
8	C24	32C24RMF	N40S	36	237	127	200	220	11.4	52	1	A	175	
9		32C24LMF	N40SL	36	237	127	200	220	11.4	52	0	A	175	
10	B24	50B24RMF	N40	40	237	127	200	220	12	65	1	B	175	—
11		50B24LMF	N40L	40	237	127	200	220	12	65	0	B	175	—
12		55B24RMF	NS60	45	237	127	200	220	12	80	1	A	175	—
13		55B24LMF	NS60L	45	237	127	200	220	12	80	0	A	175	—
14		46B24RSMF	NS60S	45	237	127	200	220	12	80	1	B	175	—
15		46B24LSMF	NS60LS	45	237	127	200	220	12	80	0	B	175	—
16	D23	55B24RMF	NX100-S6	45	237	127	200	220	12	80	1	A	175	—
17		55B24LMF	NX100-S6L	45	237	127	200	220	12	80	0	A	175	—
18		55D23RMF		60	230	173	200	220	16.5	99	1	B	147	—
19		55D23LMF		60	230	173	200	220	16.5	99	0	B	147	—
20		75D23RMF		65	230	173	200	220	16.5	99	1	B	147	—
21		75D23LMF		65	230	173	200	220	16.5	99	0	B	147	—
22	D26	80D23RMF		70	230	173	200	220	16.5	99	1	B	147	—
23		80D23LMF		70	230	173	200	220	16.5	99	0	B	147	—
24		48D26RMF	N50	50	258	173	200	220	16	80	1	B	126	—
25		48D26LMF	N50L	50	258	173	200	220	16	80	0	B	126	—
26		55D26RMF	N50Z	60	258	173	200	220	17.5	99	1	B	126	—
27		55D26LMF	N50ZL	60	258	173	200	220	17.5	99	0	B	126	—
28	D31	65D26RMF	NS70	65	258	173	200	220	17.5	112	1	B	126	—
29		65D26LMF	NS70L	65	258	173	200	220	17.5	112	0	B	126	—
30		80D26RMF	NX110-5	70	258	173	200	220	18.2	120	1	B	126	—
31		80D26LMF	NX110-5L	70	258	173	200	220	18.2	120	0	B	126	—
32	D31	65D31RMF	N70	70	304	173	200	220	20.5	126	1	B	119	—
33		65D31LMF	N70L	70	304	173	200	220	20.5	126	0	B	119	—
34		75D31RMF	N70Z	75	304	173	200	220	20.5	126	1	B	119	—
35		75D31LMF	N70ZL	75	304	173	200	220	20.5	126	0	B	119	—
36		95D31RMF	NX120-7	80	304	173	200	220	21.3	153	1	B	119	—
37	95D31LMF	NX120-7L	80	304	173	200	220	21.3	153	0	B	119	—	
38	E41	105D31RMF		90	304	173	200	220	22	160	1	B	119	—
39		105D31LMF		90	304	173	200	220	22	160	0	B	119	—
40		95E41RMF	N100	100	402	171	202	222	26	170	1	B	84	—
41	95E41LMF	N100L	100	402	171	202	222	26	170	0	B	84	—	
42	F51	115E41MF	N100Z	110	402	171	202	222	26	180	1	B	84	—
43		130E41MF	NS120	120	402	171	202	222	29	185	1	B	84	—
44	G51	135F51MF	N120MF	120	506	180	208	231	32.8	204	3	B	56	
45	H52	160G51MF	N150MF	150	506	221	210	233	39.7	255	3	B	56	
46		210H52MF	N200MF	200	515	265	215	238	49.7	340	3	B	42	—
47		74-60		53	259	176	202	202	15.4	424	0	E	144	—
48		78-72		63	269	178	182	182	16.6	504	0	E	144	—
49		78-60		60	269	178	182	182	16.6	480	0	E	144	—
50		75-72		55	240	175	190	190	14.6	440	0	B	144	—
51		68-60s		45	240	175	190	190	14	360	0	B	144	—
52		65-72S		65	301	190	170	190	19.9	520	0	B	98	—



EN Standard Battery (SMF)

No.	DIN Gr.NO.	New ETN NO.	Capacity (20HR)	Dimension(mm)				GW (kg)	R C (MINS.)	Lay-out	Terminal	Pallet Qty/	Hold-Down
				Length	Width	Height	T.Height						
1	LB1	53646MF	36	210	175	175	175	10	50	0	B	168	B3
2		53647MF	36	210	175	175	175	10	50	1	B	168	B3
3		54321MF	43	210	175	175	175	10.6	55	0	B	168	B3
4		54322MF	43	210	175	175	175	10.6	55	1	B	168	B3
5	L1	54459MF	44	210	175	190	190	10.6	66	0	B	168	B3
6		54464MF	44	210	175	190	190	10.6	66	1	B	168	B3
7	LB2	54519MF	45	240	175	175	175	14	66	0	B	168	B1/B3
8		54520MF	45	240	175	175	175	14	66	1	B	168	B1/B3
9		55046MF	50	240	175	175	175	14.6	75	1	B	168	B1/B3
10		55457MF	54	240	175	175	175	14.52	90	0	B	168	B1/B3
11	L2	55459MF	54	240	175	175	175	14.52	90	1	B	168	B1/B3
12		56077MF	60	240	175	175	175	15.18	98	0	B	168	B1/B3
13		55559MF	55	240	175	190	190	14.6	93	0	B	168	B1/B3
14		55548MF	55	240	175	190	190	14.6	93	1	B	168	B1/B3
15		55565MF	55	240	175	190	190	14.6	93	1	B	168	B1/B3
16		55531MF	55	240	175	190	190	14.6	93	0	B	168	B1/B3
17		56219MF	62	240	175	190	190	15.2	105	0	B	168	B1/B3
18		56220MF	62	240	175	190	190	15.2	105	1	B	168	B1/B3
19	56221MF	62	240	175	190	190	15.2	105	0	B	168	B1/B3	
20	LB3	55415MF	54	274	175	175	175	15.5	93	0	B	144	B3
21		56318MF	63	274	175	175	175	16.8	115	0	B	144	B3
22		56420MF	64	274	175	175	175	16.8	115	0	B	144	B3
23		56818MF	68	274	175	175	175	17.5	123	0	B	144	B3
24		56821MF	68	274	175	175	175	17.5	123	0	B	144	B3
25		56828MF	68	274	175	175	175	17.5	123	1	B	144	B3
26		57113MF	71	274	175	175	175	17.5	123	0	B	144	B3
27	57114MF	71	274	175	175	175	17.5	123	1	B	144	B3	
28	L3	56638MF	66	274	175	190	190	16.8	112	0	B	144	B3
29		56633MF	66	274	175	190	190	16.8	112	1	B	144	B3
30		57219MF	72	274	175	190	190	17.5	123	1	B	144	B3
31		57220MF	72	274	175	190	190	17.5	123	0	B	144	B3
32		57412MF	74	274	175	190	190	17.5	135	0	B	144	B3
33		57413MF	74	274	175	190	190	17.5	135	1	B	144	B3
34		57524MF	75	274	175	190	190	17	135	0	B	144	B1/B3
35	57539MF	75	274	175	190	190	17	135	0	B	120	B1/B3	
36	L4	58043MF	80	311	175	190	190	19.5	135	0	B	120	B1/B3
37	LB5	58515MF	85	354	175	175	175	21.5	135	0	B	96	B1/B3
38	L5	58827MF	88	350	175	190	190	22.1	150	0	B	96	B1/B3
39		58821MF	88	350	175	190	190	22.1	150	1	B	96	B1/B3
40		60038MF	100	350	175	190	190	22.7	170	0	B	96	B3
41	60044MF	100	350	175	190	190	22.7	170	1	B	96	B3	
42	JIS B20 (NS40Z)	53504MF	35	196	128	200	220	10.3	52	0	B	224	—
43		53520MF	35	196	128	200	220	10.3	52	0	B	224	—
44		53522MF	35	196	128	200	220	10.3	52	1	B	224	—
45		53521MF	35	196	128	200	220	10.3	52	0	B	224	—
46	JIS B24 (NS60)	54026MF	40	196	128	200	220	10.9	65	0	B	224	—
47		54027MF	40	196	128	200	220	10.9	65	1	B	224	—
48		54523MF	45	237	128	200	220	12.6	80	0	B	175	—
49	54524MF	45	237	128	200	220	12.6	80	1	B	175	—	
50	54584MF	45	237	128	200	220	12.6	80	0	B	175	—	
51	54551MF	45	237	128	200	220	12.6	80	1	B	175	—	
52	JIS D23 (55D23)	56068MF	60	230	173	202	224	16.5	95	0	B	126	—
53	56069MF	60	230	173	202	224	16.5	95	1	B	126	—	

54	JIS D26 (N50z)	56048MF	60	263	173	198	218	17.52	95	0	B	126	—
55		56049MF	60	263	173	198	218	17.52	95	1	B	126	—
56		57029MF	72	263	173	198	218	18.2	105	0	B	126	—
57	JIS D31 (N70)	57024MF	72	263	173	198	218	18.2	105	1	B	126	—
58		57512MF	75	302	174	200	220	20.5	95	0	B	119	—
59		57513MF	75	302	174	200	220	20.5	115	1	B	119	—
60		58513MF	85	302	174	200	220	22	115	0	B	119	—
61		58514MF	85	302	174	200	220	22	115	1	B	119	—
62		59518MF	95	302	174	200	220	22.8	120	1	B	119	—
63		59519MF	95	302	174	200	220	22.8	120	0	B	119	—
64	Q58	55716MF	57	240	175	153	175	12.9	95	0	B	135	—
65		56011MF	60	240	175	153	175	13.5	105	0	B	135	—
66	D2	59615MF	96	347	173	210	230		125	0	B	84	—
67		59616MF	96	347	173	210	230		125	1	B	84	—
68		60527MF	105	347	173	210	230		175	1	B	84	—
69		60528MF	105	347	173	210	230		175	0	B	84	—
70	JIS E41 (N100)	60026MF	100	405	170	200	220	26	170	0	B	84	—
71		60035MF	100	405	170	200	220	26	170	1	B	84	—
72		61017MF	110	405	170	200	220	27.55	170	0	B	84	—

Truck Battery Specification

No.	DIN Gr.NO.	New ETN NO.	Capacity (20HR)	Dimension(mm)				GW (kg)	R C (MINS.)	Lay-out	Terminal	Qty/Pallet	Hold-Down
				Length	Width	Height	T.Height						
1	D4	62034MF	120	505	184	194	215	32.8	204	3	B	63	—
2		62038MF	120	505	184	194	215	32.8	204	4	B	63	—
3		64020MF	140	505	184	194	215	34.2	228	3	B	63	—
4		64028MF	140	505	184	194	215	34.2	228	4	B	63	—
5		65011MF	150	505	220	192	214	40.5	260	3	B	63	—
6	D5	65012MF	150	505	220	192	214	40.5	260	4	B	63	—
7		67043MF	170	505	220	192	214	41.2	270	3	B	63	—
8		67044MF	170	505	220	192	214	41.2	270	4	B	63	—
9		68022MF	180	505	220	192	214	41.2	270	3	B	63	—
10		68029MF	180	505	220	192	214	41.2	270	4	B	63	—
11		68039MF	180	515	265	215	235	48.2	305	3	B	35	—
12	D6	68040MF	180	515	265	215	235	48.2	305	3	B	35	—
13		70027MF	200	515	265	215	235	49.7	320	3	B	35	—
14		70029MF	200	515	265	215	235	49.7	320	4	B	35	—
15		71014MF	210	515	265	215	235	50.4	340	3	B	35	—
16		71015MF	210	515	265	215	235	50.4	340	3	B	35	—
17		72511MF	225	515	265	215	235	51.2	355	3	B	35	—
18		73010MF	230	515	265	215	235	51.2	355	3	B	35	—
19	D8	73011MF	230	515	265	215	235	51.2	355	3	B	35	—
20		61015MF	110	511	175	210	210	31.3	187	3	B	63	—
21		61023MF	120	511	175	210	210	32	204	4	B	63	—
22	D9	64323MF	143	513	217	210	210	34.2	255	3	B	63	—
23		65032MF	150	513	217	210	210	39.7	260	4	B	63	—



AUTOMOTIVE BATTERY



BCI Standard Battery (SMF)

Table with 14 columns: No., Gr.NO., TYPE NO., Capacity 20HR(AH), CCA, RC, Dimension(mm) (Length, Width, Height, T.Height), Lay-out, Terminal, Qty/pallet, Hold-down. Rows 1-60.

AS Standard Battery(SMF)

Table with 14 columns: No., TYPE NO., Capacity (20HR), Dimension(mm) (Length, Width, Height, T.Height), R C (MINS.), Lay-out, Terminal, Qty /Pallet, Hold-Down. Rows 1-41.

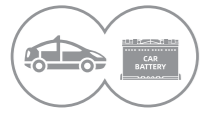

SA Standard Battery(SMF)

No.	MODEL NO.	Capacity (20HR)	Dimension(mm)				R C (MINS.)	Lay-out	Terminal	Qty/ Pallet	Hold-Down
			Length	Width	Height	T.Height					
1	610	45	230	177	203	203	69	0	B1	126	B1
2	611	45	230	177	203	203	69	1	B1	126	B1
3	612CV	45	240	174	190	190	69	0	B1	168	B3
4	617	36	208	174	175	175	50	0	B	168	B3
5	618	36	208	174	175	175	50	1	B	168	B3
6	619	36	208	174	175	175	50	1	B	168	B3
7	621	50	261	177	203	203	77	1	B	126	B1
8	622	50	261	177	203	203	77	0	B	126	B1
9	628	45	240	174	177	177	62	1	B	168	B3
10	629	45	240	174	177	177	62	1	B	168	B3
11	630	36	238	134	202	202	50	0	B	175	B1
12	631	36	238	134	202	202	50	1	B	175	B1
13	634	45	238	134	202	202	62	0	B	175	B1
14	635	45	240	174	177	177	62	0	B	168	B3
15	636CV	45	241	134	203	203	62	1	B	168	B1
16	637CV	60	235	173	203	203	90	0	B	147	B1
17	638	60	230	177	203	203	90	0	B	126	B1
18	639	60	230	177	203	203	90	1	B	126	B1
19	643	60	240	175	190	190	90	0	B	168	B3
20	645	60	240	175	190	190	90	1	B	168	B3
21	646	60	240	175	190	190	90	1	B	168	B3
22	647CV	54	284	175	175	175	77	1	B	144	B3
23	649	65	230	170	227	227	97	1	B	147	B1
24	650	65	305	173	220	220	97	0	B	119	B1
25	651CV	60	275	175	175	175	91	1	B	144	B3
26	652CV	65	278	175	190	190	104	1	B	144	B3
27	653	65	278	175	190	190	104	1	B	144	B3
28	654CV	80	350	175	175	175	127	1	B	84	B3
29	657CV	65	278	175	190	190	104	0	B	144	B3
30	674	90	332	171	218	252	149	1	B	84	B3
31	674J	90	332	171	218	252	149	1	B	84	B3
32	674(A31)	90	332	171	218	252	149	1	B	168	B3
33	659CV	80	315	175	175	175	127	0	B	84	B3
34	665	60	242	175	190	190	90	1	B	168	B3
35	667	65	278	175	190	190	104	1	B	144	B3
36	668	90	315	175	190	190	149	1	B	84	B3
37	680/3	120	510	180	219	219	216	4	B	48	
38	681/2	120	510	180	219	219	216	3	B	48	
39	685	120	504	180	214	214	225	4	B	48	
40	687	200	515	264	235	235	340	4	B	36	
41	688	200	515	264	235	235	340	3	B	36	
42	689	140	512	224	219	219	265	4	B	48	
43	690	140	512	224	219	219	265	3	B	48	
44	692	165	512	224	219	219	331	4	B	48	



AGM Start Stop Batteries

No.	Item	Case Type	Capacity	CCA	Dimension(mm)	Lay-out	Terminal	Hold-Down
			(20Hr)	-18 °C	L*W*H*TH			
1	AGML2	L2DIN	60	660	240*175*190*190	0	B	B3
2	AGML3	L3DIN	70	720	276*175*190*190	0	B	B3
3	AGML4	L4DIN	80	800	314*175*190*190	0	B	B3
4	AGML5	L5DIN	92	850	354*175*190*190	0	B	B3
5	AGML6	L6DIN	105	950	394*175*190*190	0	B	B3

EFB Start Stop Batteries

No.	Item	Case Type	Capacity	CCA	Dimension(mm)	Lay-out	Terminal	Hold-Down
			(20Hr)	-18 °C	L*W*H*TH			
1	EFBM42	B20JIS	35	310	195*127*200*220	0/1	A	—
2	EFBN55	B24JIS	40	370	237*127*200*220	0/1	A/B	—
3	EFBQ85	D23JIS	60	610	230*173*200*220	0/1	B	—
4	EFBS95	D26JIS	64	645	258*173*200*220	0/1	B	—
5	EFBT110	D31JIS	75	655	304*173*200*220	0/1	B	—
6	EFBL2	L2DIN	60	640	240*175*190*190	0	B	—
7	EFBL3	L3DIN	70	700	276*175*190*190	0	B	B3
8	EFBL4	L4DIN	80	750	314*175*190*190	0	B	B3
9	EFBL5	L5DIN	92	800	354*175*190*190	0	B	B3
10	EFBL6	L6DIN	105	850	394*175*190*190	0	B	B3



TERMINAL AND HOLD DOWN FOR THE AUTOMOTIVE BATTERY



TERMINAL TYPE

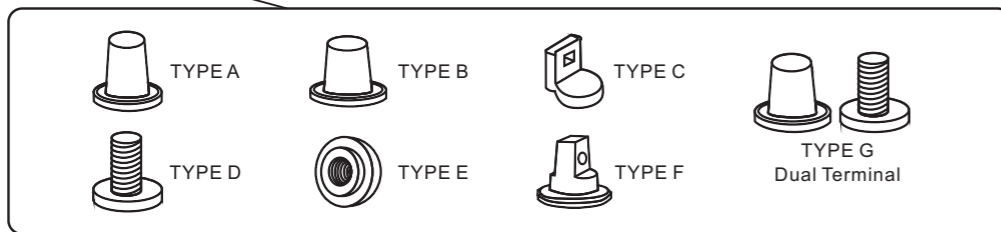

HOLD DOWNS

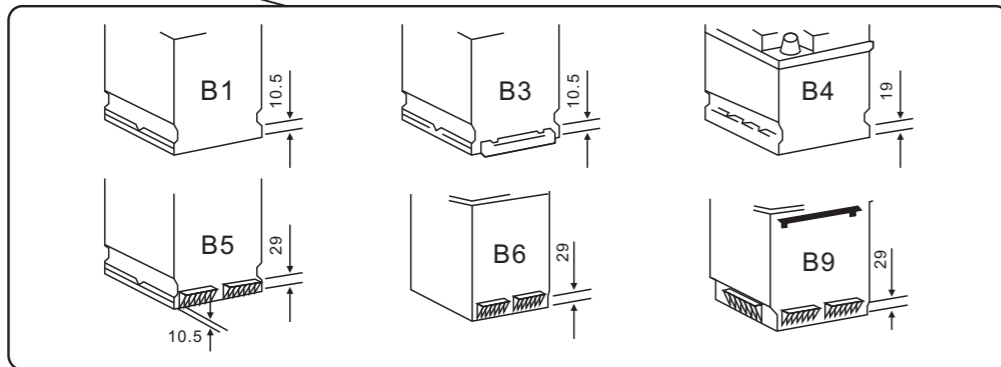

CELL LAYOUT

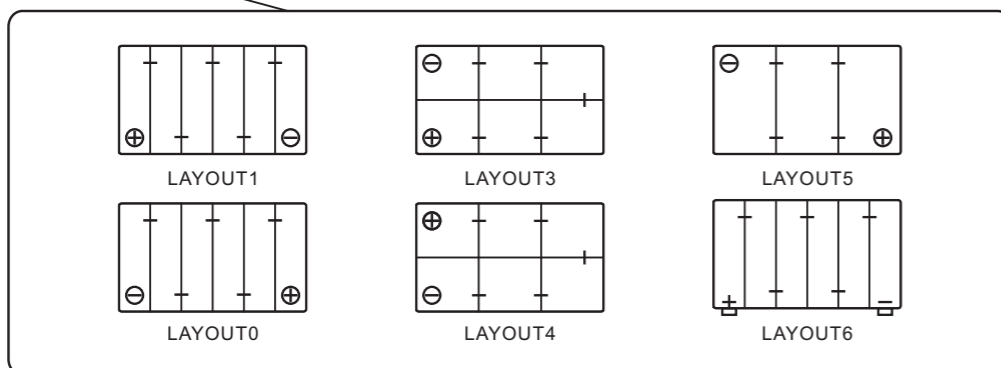

BATTERY, WET,
FILLED WITH ACID UN2794



DANGER/POISON



SHIELD EYES. EXPLOSIVE GASES CAN CAUSE BLINDNESS OR INJURY.
SE PROTÉGER LES YEUX. LES GAZ EXPLOSIFS PEUVENT ENTRAINER LA CECITE OU DE GRAVES BLESSURES.
PROTEJA LOS OJOS. GASES EXPLOSIVOS PUEDEN PRODUCIR CEGUERA O LESIONES.



NO SPARKS, FLAMES OR SMOKING.
PAS D' ETINCELLES, DE FLAMMES. NE PAS FUMER.
NO FUMAR NI HACER CHISPAS O LLAMAS.



SULFURIC ACID CAN CAUSE BLINDNESS OR SEVERE BURNS.
L' ACIDE SULFURIQUE PEUT CAUSER LA CECITE OU DES BRULURES GRAVES.
EL ÁCIDO SULFÚRICO PUEDE CAUSAR CEGUERA O LESIONES GRAVES.



FLUSH EYES IMMEDIATELY WITH WATER. GET MEDICAL HELP FAST.
RINCER IMMEDIATEMENT LES YEUX AVEC DE L' EAU. APPELER IMMEDIATEMENT UN MEDECIN.
ENJUGUE LOS OJOS INMEDIATAMENTE CON AGUA Y LLAME DE INMEDIATO A UN MÉDICO.

KEEP OUT OF THE REACH OF CHILDREN. DO NOT TIP. DO NOT OPEN BATTERY.
GARDER HORS DE LA PORTEE DES ENFANTS. NE PAS INCLINER. NE PAS OUVRIR LA BATTERIE.
MANTENGASE FUERA DEL ALCANCE DE LOS NIÑOS. NO INCLINE NI ABRA LA BATERÍA.

HOW TO REPLACE BATTERY

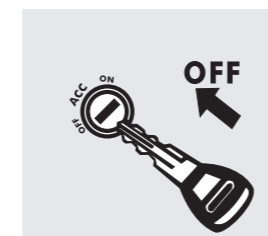

1. Switch off the engine and keep sparks, flames, cigarettes away from battery at all times, before removing the old battery.

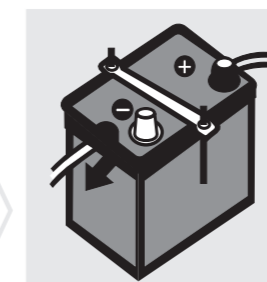

2. Disconnect the negative terminal, first and avoid short-circuit caused by tools, when removing old battery.

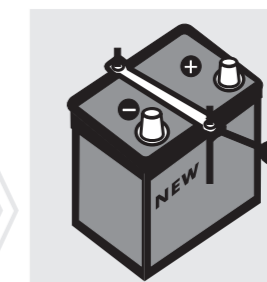

3. Clean corroded parts in tray and cable clamps, before installation of new battery.

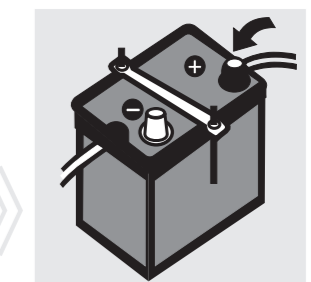

4. Connect the positive terminal, first and check the terminal clamps for tight fit, when installing new battery.



AUTOMOTIVE BATTERY

AOKLY
Series Battery



SALES NETWORK

We have a good team, including our workers, our customer and consumer. We are together to make efforts and to enjoy the achievement.

In Overseas market, we open selling branches in West Africa and Middle East. And our products are widely exported to Canada, Italy, Germany, Netherland, Greece, Cyprus, Spain, Russia, etc; In South America, we have customers in Chile, Peru, Cuba, Jamaica, Suriname, etc; In Africa, South Africa, Nigeria, Cameroon, Ghana, Angola, Algeria, Sudan etc, In Middle east, UAE, Saudi Arabia, Yemen, Iraq, Kuwait, Iran etc..



Aokly Power Brands



AOKLY BATTERY



NEW EARTH BATTERY



FORGO BATTERY



NEDAR BATTERY



DAD BATTERY



AK BATTERY

Professional
Storage Battery
Manufacturer

